

# Lister och tätningar för alla applikationer inom kyl- och frys

## Tätningslister av högsta kvalitet. Standard eller måttbeställt.

Det finns tätningsprofiler i alla former och storlekar. Sortimentet är indelat i tre grupper: PVC, gummi och silikon. PVC-profiler är därefter uppdelade efter form och fästmetod.

PVC-profiler används i kyldörrar, kylbänkar, kyl- och frysskåp, kylrum etc. De finns i följande fyra kategorier: Snap-in profiler, klaffprofiler, läppprofiler och kompressionsprofiler. Förutom PVC finns profiler av gummi och silikon. Gummiprofiler är lämpliga för tätning av slagdörrar eller skjutdörrar i kylrum. Silikonprofiler används ofta i ugnar eller frysar på grund av värmeteransen hos materialet.

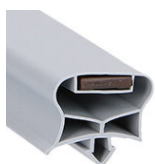

### Snap-in profil PVC

Den vanligaste profilen är Snap-in. Denna profiltyp har en pil (pilhuvud) med "tänder" som hakar fast i skåran när den trycks in ordentligt. De flesta av dessa Snap-in profiler har en separat ficka för en magnet.

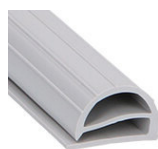

### Kompressionsprofil PVC

Kompressionsprofiler har ingen magnet och monteras med samma metod som klaff- och läppprofiler. Kompressionsprofiler hålls på plats bakom en metallhållarplatta eller -list, som sedan fästs med skruvar eller popnitar.

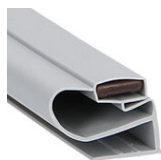

### Klaffprofil PVC

Klaffprofiler kan identifieras av klaffen vid profilens bas. Vid montering av denna typ av tätning hålls denna klaff fast av en metallplatta. Plattan monteras på dörren med skruvar, popnitar eller häftklamrar för att hålla tätningen på plats. De flesta klaffprofiler har en ficka för en magnet.



### Läppprofil PVC

Där klaffprofiler har en platt klaff fäst vid basen av profilen har läppprofiler en läpp som hjälper till att säkra placeringen av tätningen under och efter installationen. Läppprofiler fästs bakom en metallplatta eller -list, som sedan monteras med skruvar eller popnitar. De flesta läppprofiler har en ficka för en magnet.



### Gummiprofil

På grund av gummits egenskaper används det ofta i kylrum. Gummi kan inte svetsas som PVC, så ett speciellt gummilim används för att sammanfoga delarna. Gummiprofiler finns även per meter på rulle. För vissa gummiprofiler finns hörnstycken som kan användas för att skapa en 90° vinkel vid montering av en ny gummitätning på en kylrumsdörr. Gummiprofiler med klaff monteras på samma sätt som PVC klaffprofiler. Profiler med "pil" installeras som Snap-in profilerna. För vissa gummiprofiler finns fästlister.



### Silikonprofil

Profiler av silikon har en bred temperaturtolerans och kan därför användas i frysar och ugnar. Temperaturintervallet är från -40 till 280 °C. Används bl a i ugnar, kombiugnar, ångkokare och frysskåp. Silikon kan inte svetsas som PVC utan ett speciellt lim används för att foga ihop delarna. Silikonprofiler kan även beställas per meter på rulle. Profiler med klaff monteras på samma sätt som PVC klaffprofiler. Silikonprofiler med "pil" installeras som Snap-in profilerna.

## Snap-in profiler med magnet

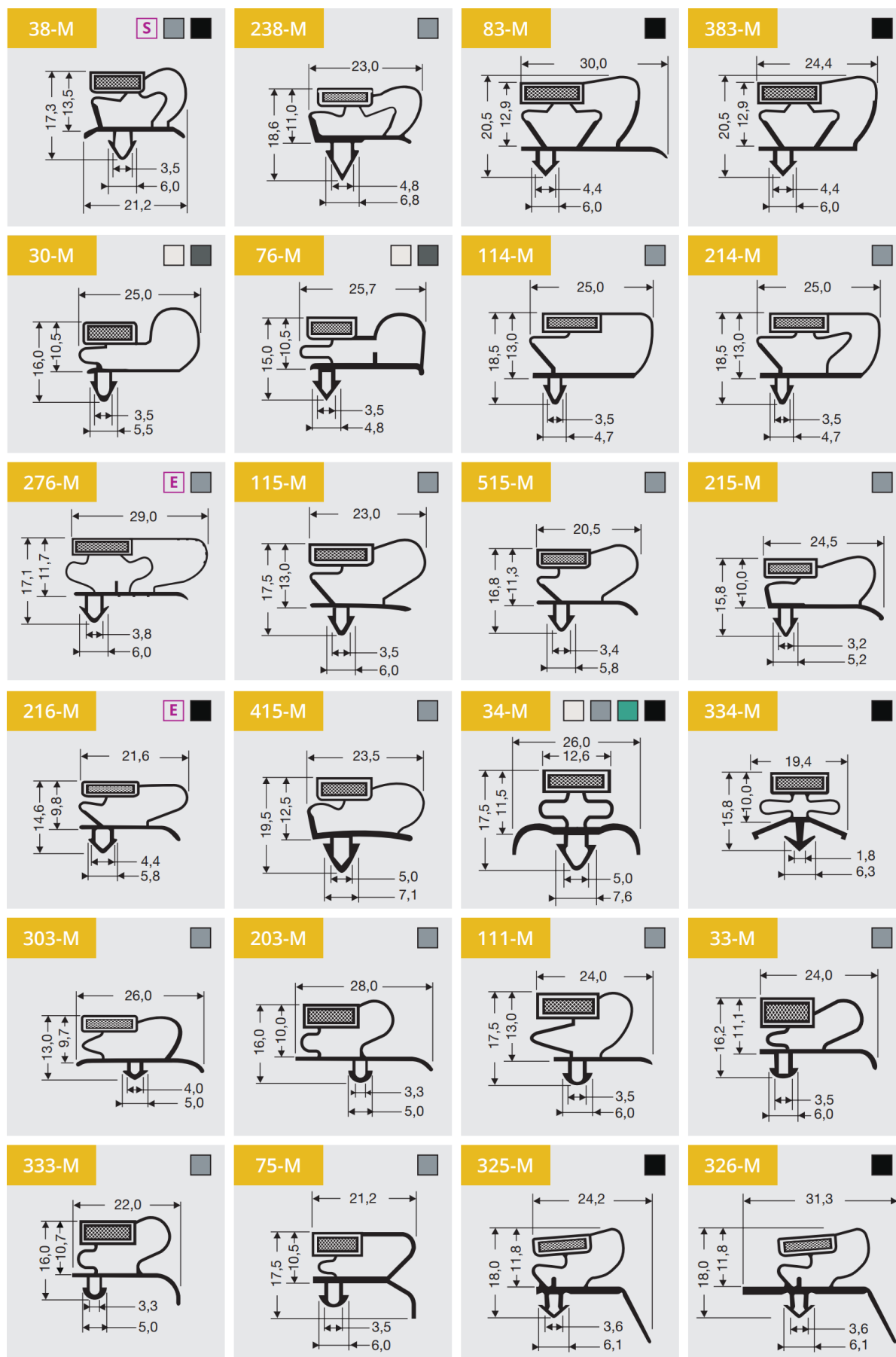

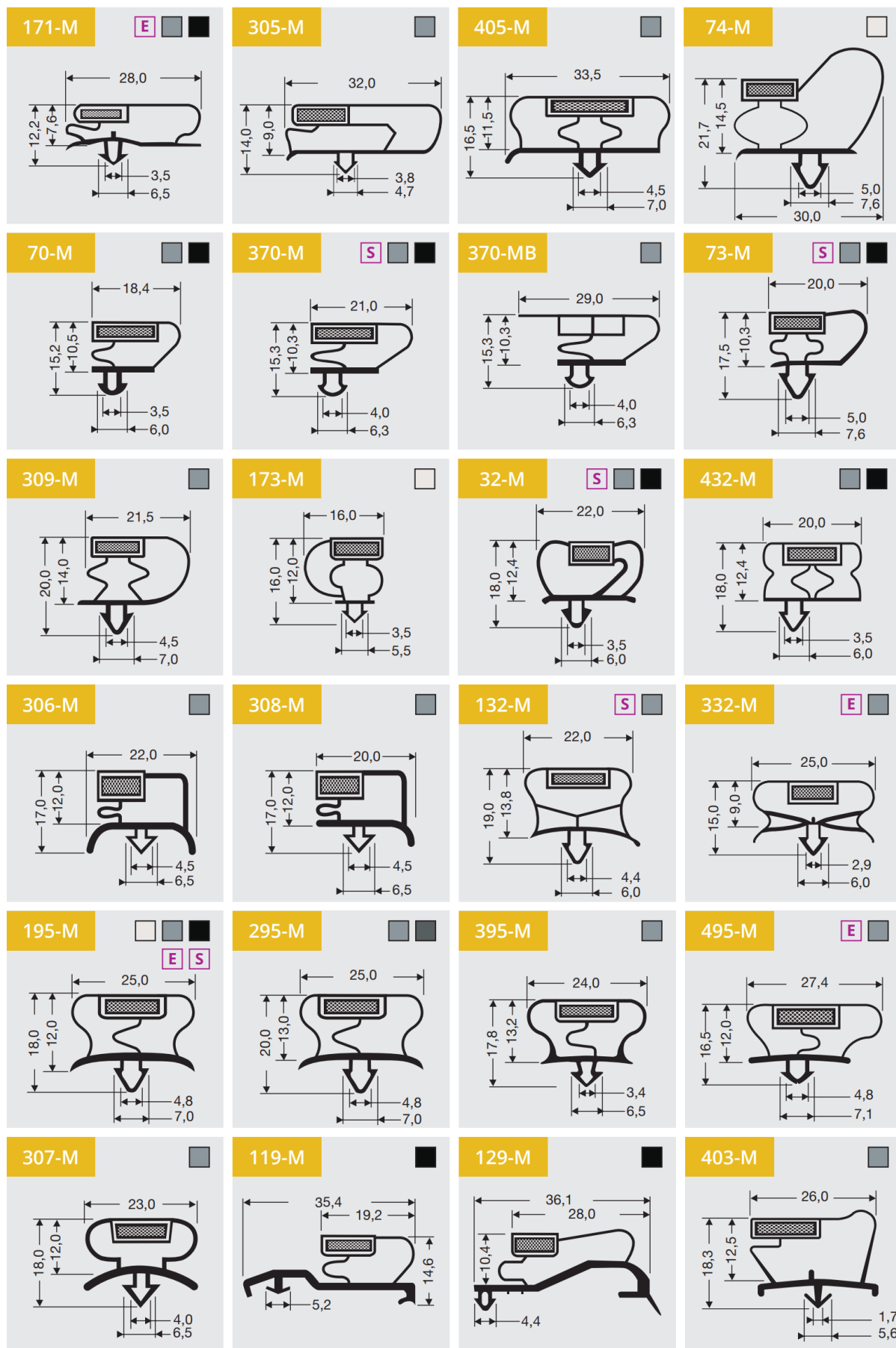

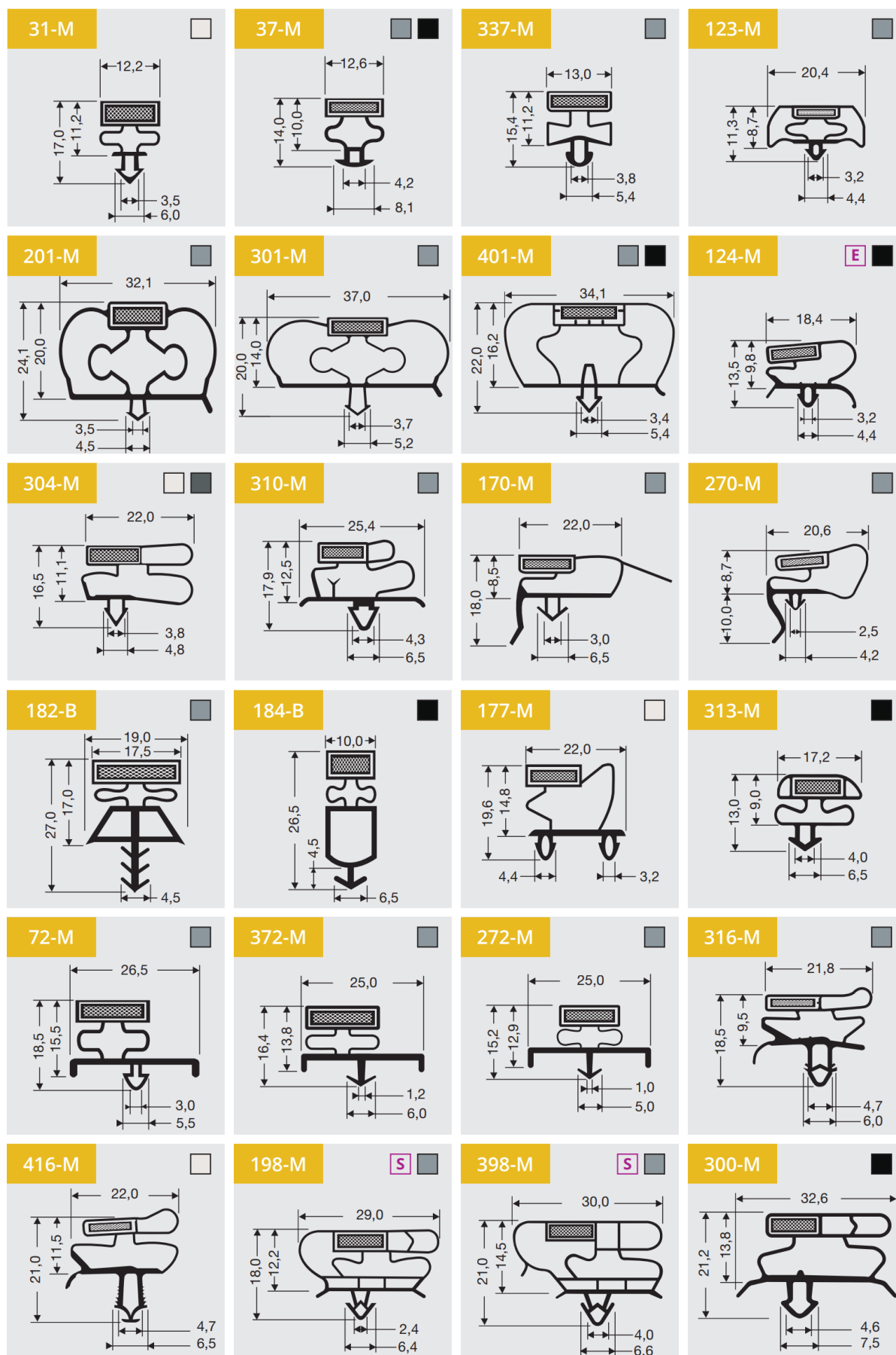

Snap-in profiler med magnet (stor pil)

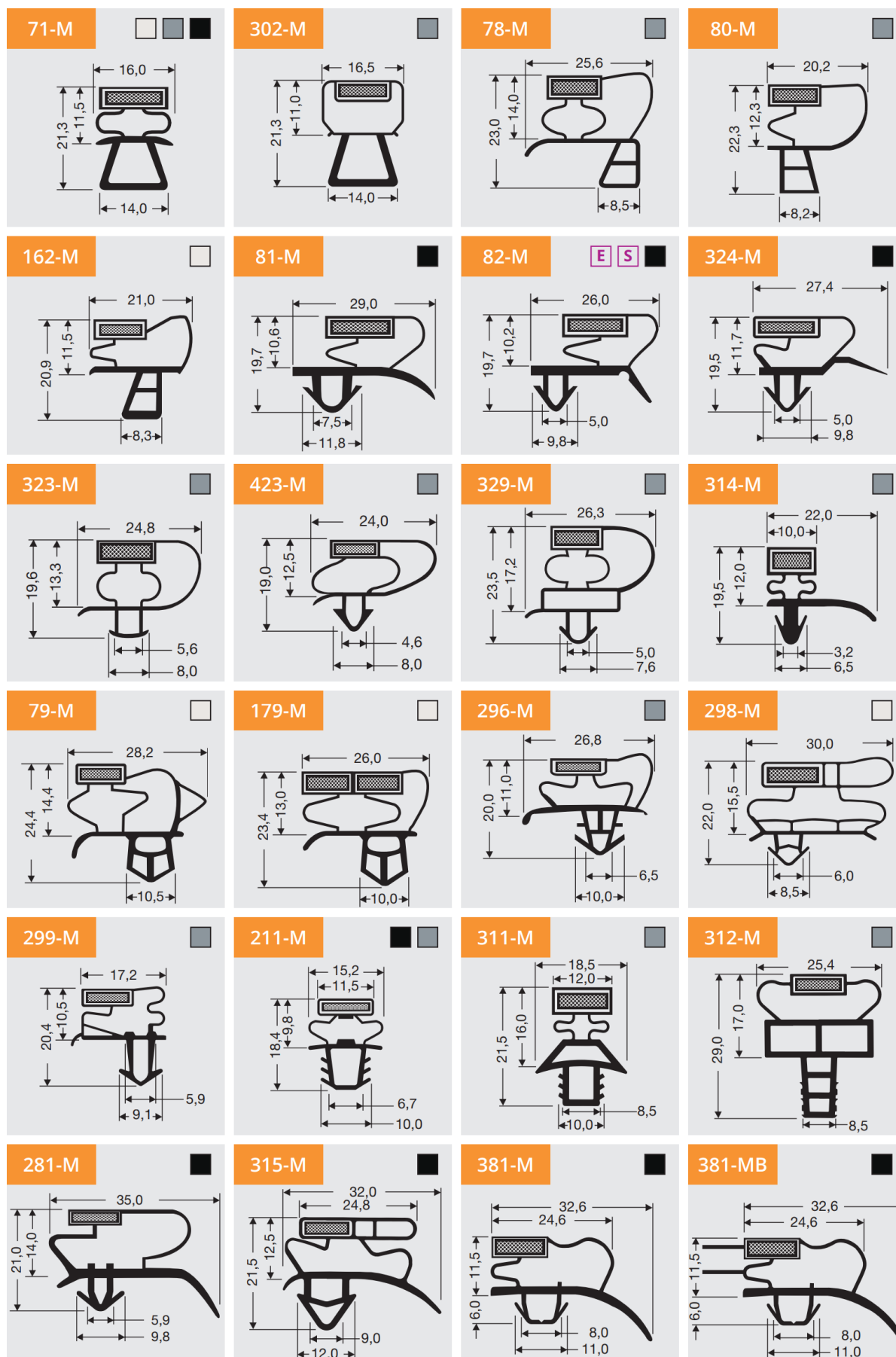

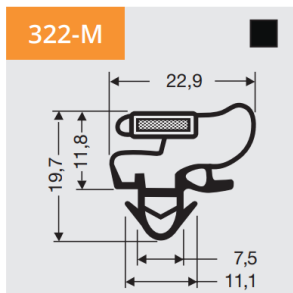
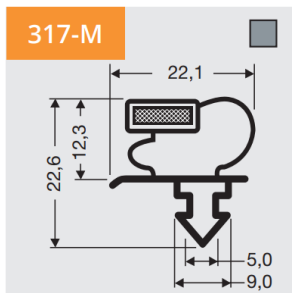
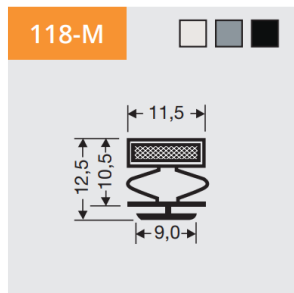
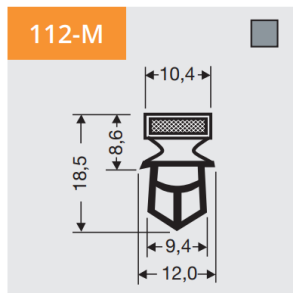

**Snap-in profiler utan magnet**

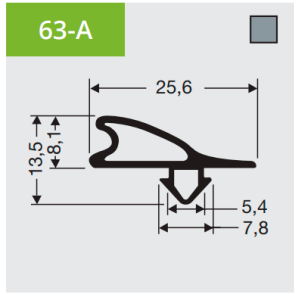
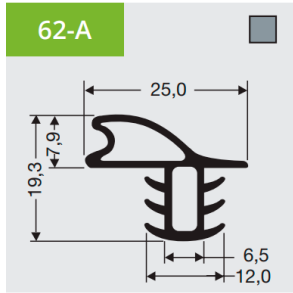
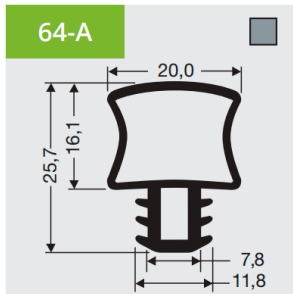
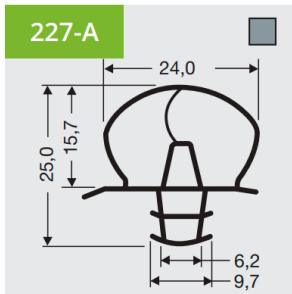
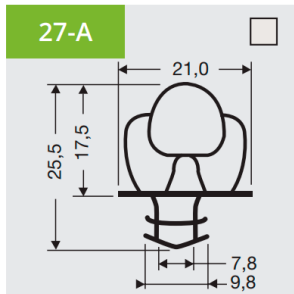
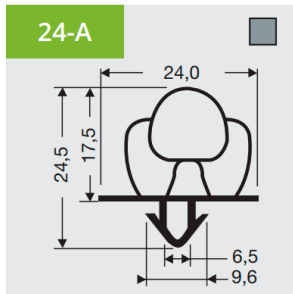
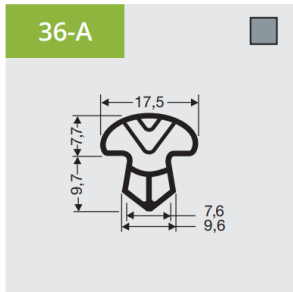
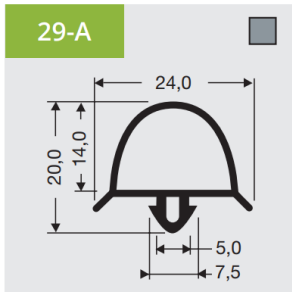
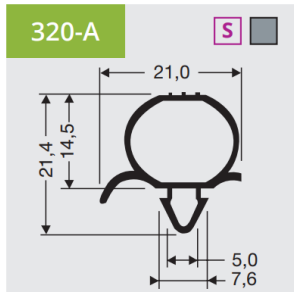
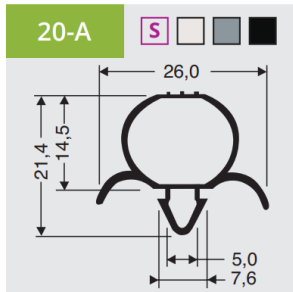
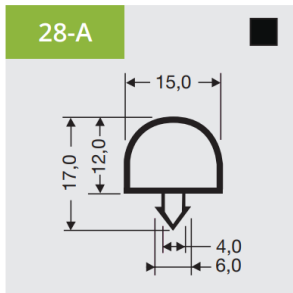
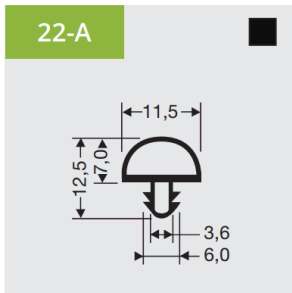
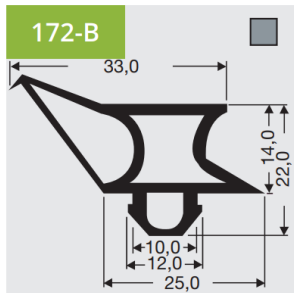
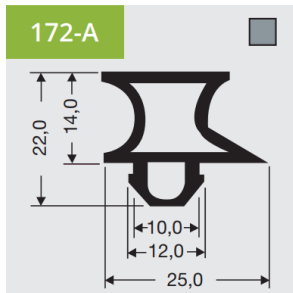
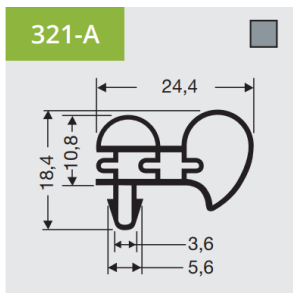
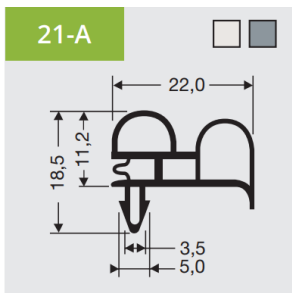
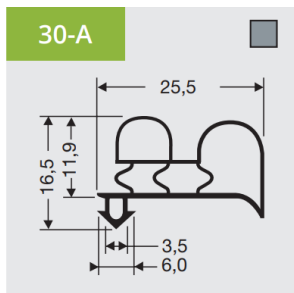
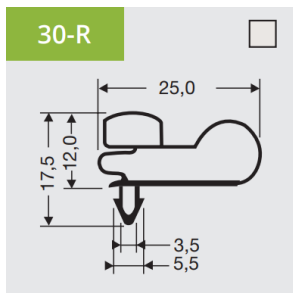

## Klaffprofiler med magnet

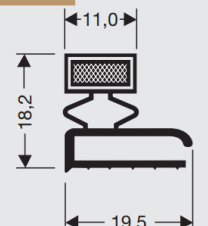
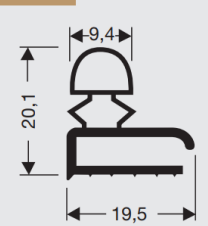
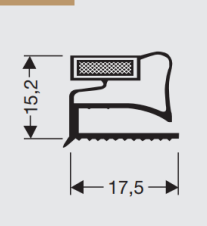
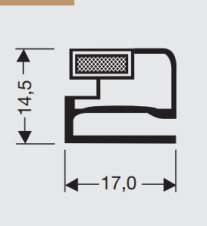
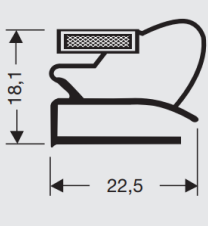
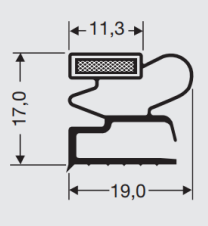
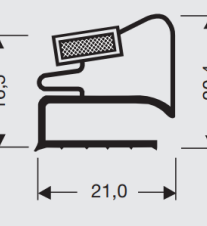
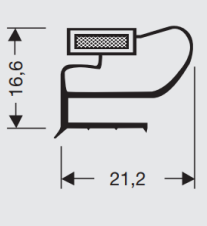
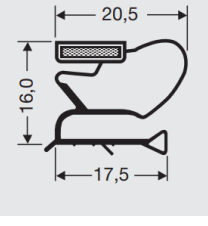
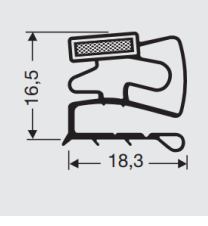
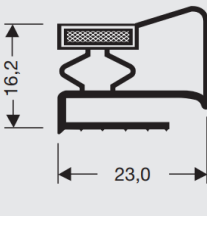
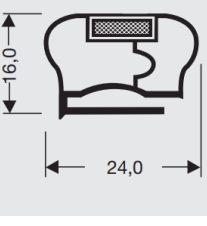
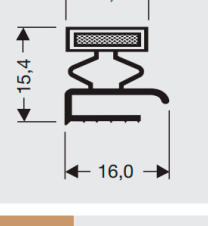
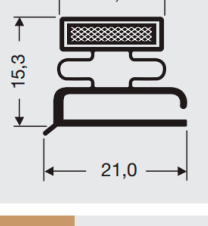
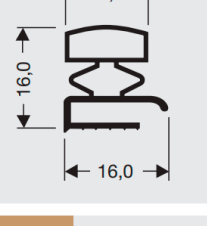
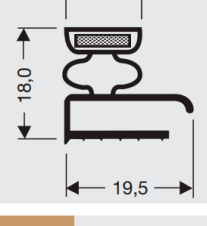
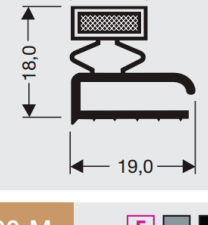
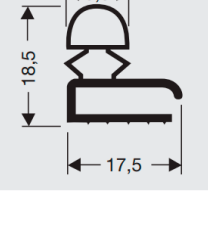
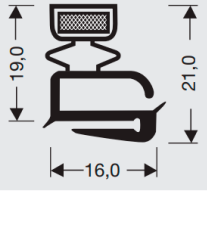
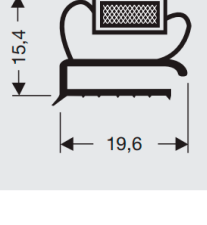
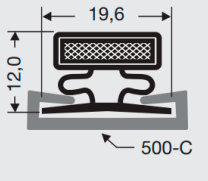
<p><b>15-M</b> <input type="checkbox"/></p> 	<p><b>15-R</b> <input type="checkbox"/></p> 	<p><b>128-M</b> <input checked="" type="checkbox"/> <input checked="" type="checkbox"/></p> 	<p><b>35-M</b> <input type="checkbox"/></p> 
<p><b>121-M</b> <input type="checkbox"/> <input type="checkbox"/></p> 	<p><b>328-M</b> <input type="checkbox"/></p> 	<p><b>127-M</b> <input type="checkbox"/></p> 	<p><b>135-M</b> <input type="checkbox"/> <input type="checkbox"/></p> 
<p><b>136-M</b> <input checked="" type="checkbox"/> <input type="checkbox"/> <input type="checkbox"/></p> 	<p><b>137-M</b> <input type="checkbox"/></p> 	<p><b>105-M</b> <input type="checkbox"/></p> 	<p><b>17-M</b> <input type="checkbox"/></p> 
<p><b>18-M</b> <input type="checkbox"/> <input type="checkbox"/> <input type="checkbox"/> <input checked="" type="checkbox"/></p> 	<p><b>318-M</b> <input type="checkbox"/> <input type="checkbox"/></p> 	<p><b>18-R</b> <input type="checkbox"/></p> 	<p><b>25-M</b> <input type="checkbox"/> <input type="checkbox"/></p> 
<p><b>45-M</b> <input type="checkbox"/></p> 	<p><b>45-R</b> <input type="checkbox"/></p> 	<p><b>100-M</b> <input type="checkbox"/></p> 	<p><b>19-M</b> <input type="checkbox"/> <input type="checkbox"/> <input checked="" type="checkbox"/></p> 
<p><b>500-M</b> <input checked="" type="checkbox"/> <input type="checkbox"/> <input checked="" type="checkbox"/></p>  <p>500-C</p> <p><b>!</b> In combination with profile 500-C</p>			

## Läppprofiler med magnet (popnit/skruv)

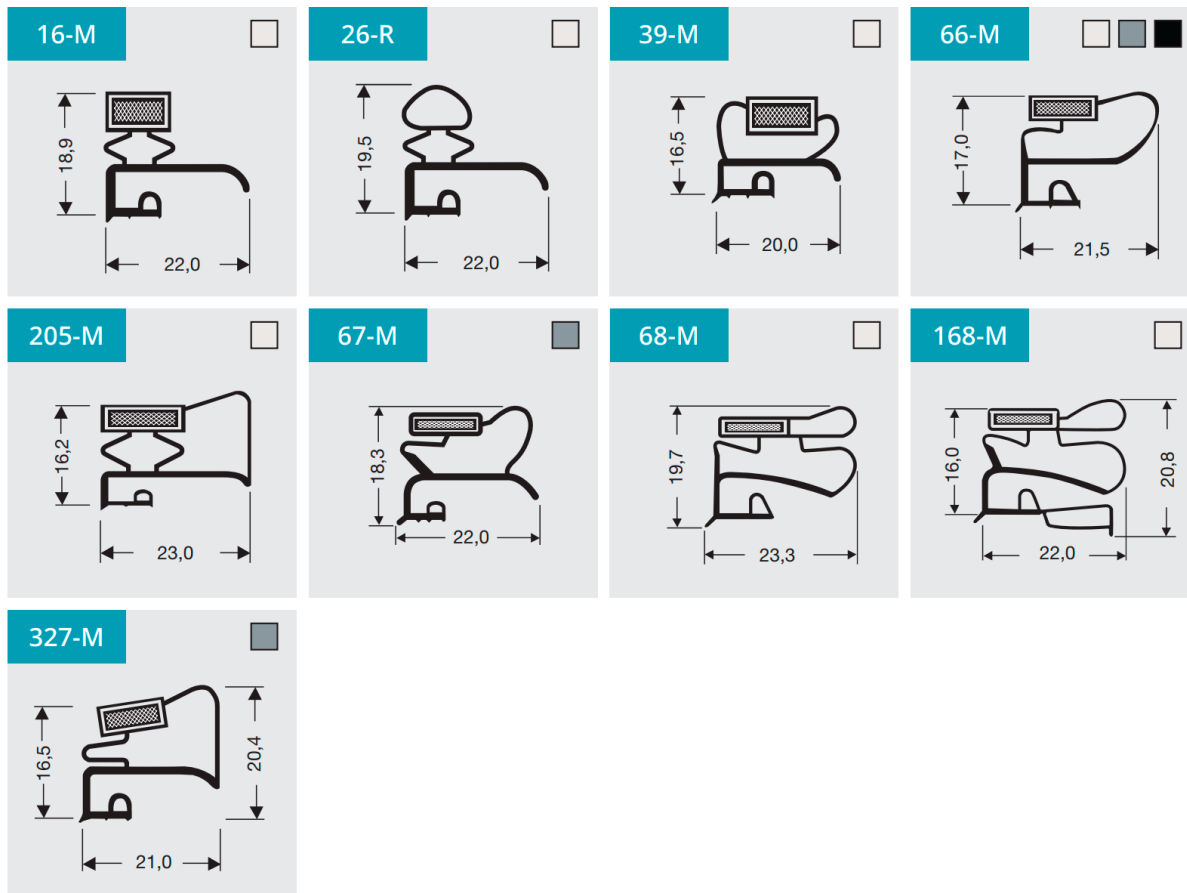



**Kompressionsprofiler utan magnet**

<p><b>4-A</b> </p> 	<p><b>6-A</b> </p> 	<p><b>7-A</b> </p> 	<p><b>9-A</b> </p> 
<p><b>10-A</b> </p> 	<p><b>210-A</b> </p> 	<p><b>122-A</b> </p> 	<p><b>5-A</b> </p> 
<p><b>102-A</b> </p> 	<p><b>104-A</b> </p> 	<p><b>158-A</b> </p> 	<p><b>169-A</b> </p> 
<p><b>8-A</b> </p> 	<p><b>19-A</b> </p> 	<p><b>138-A</b> </p> 	<p><b>23-A</b> </p> 
<p><b>500-A</b> </p>  <p><b>500-C</b></p> <p> In combination with profile 500-C</p>			

## Silikonprofiler



**Gummiprofiler**

<p><b>1-A</b></p>	<p><b>2-A</b></p>	<p><b>3-A</b></p>	<p><b>11-A</b></p>
<p><b>12-A</b></p>	<p><b>48-A</b></p>	<p><b>50-A</b></p> <p>! Available per profile length of 5 meters</p>	<p><b>51-A</b></p> <p>! As frame or per profile length of 5 meters</p>
<p><b>52-A</b></p>	<p><b>164-A</b></p> <p>! Available as frame or by the meter.</p>	<p><b>54-A</b></p>	<p><b>58-A</b></p>
<p><b>47-A</b></p>	<p><b>45-B</b></p>	<p><b>46-A</b></p>	<p><b>46-B</b></p>
<p><b>47-B</b></p>	<p><b>43-A28</b></p>	<p><b>43-A36</b></p>	<p><b>43-A38</b></p>
<p><b>43-A20</b></p>	<p><b>43-C</b></p>	<p><b>43-C</b></p>	<p><b>43-C</b></p>

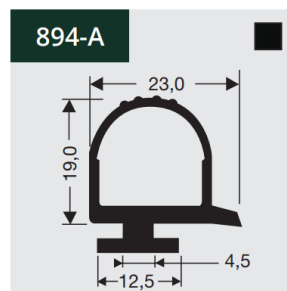
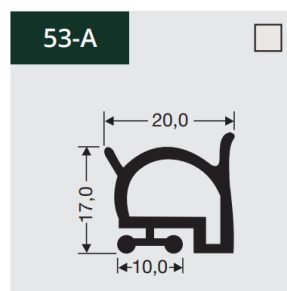
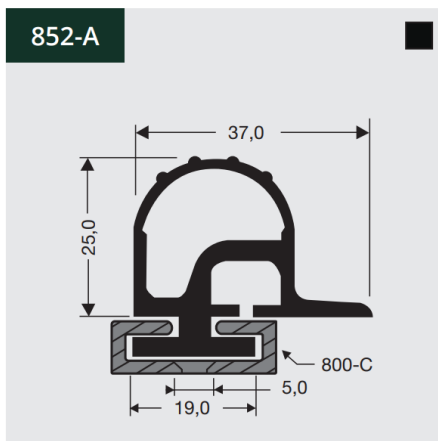
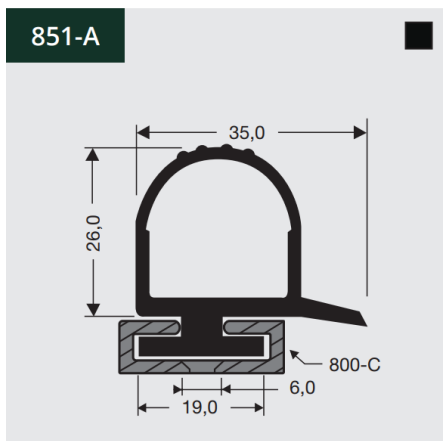
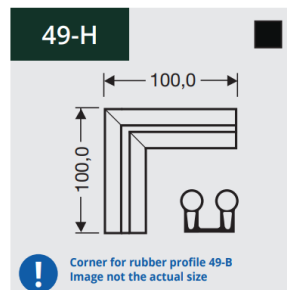
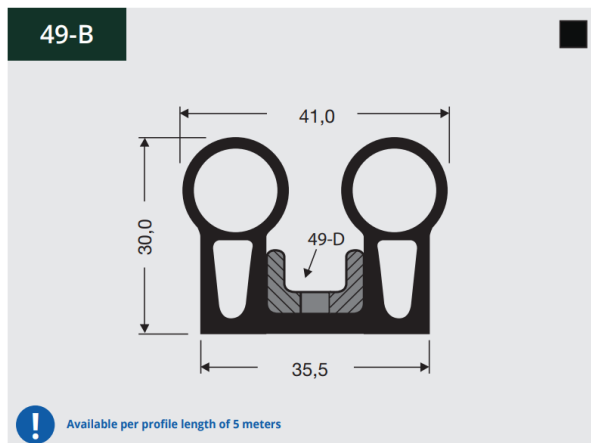
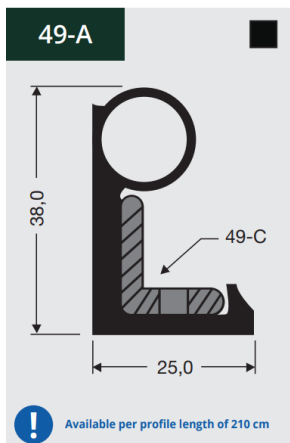
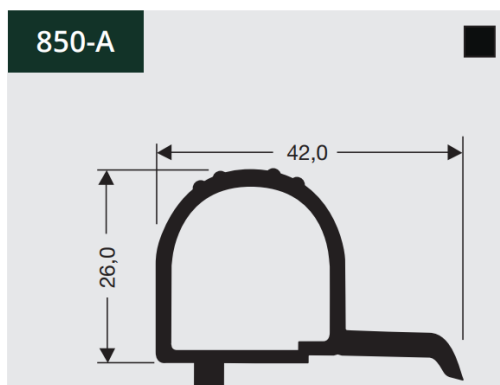
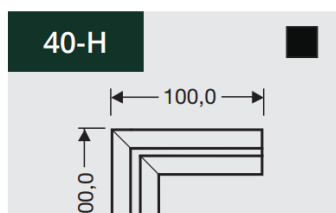
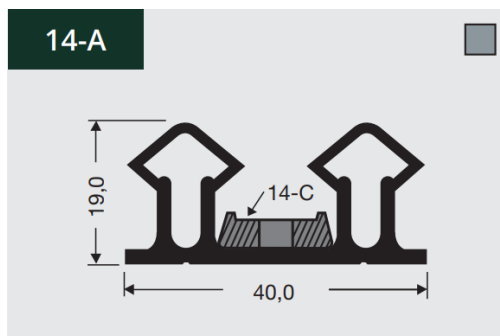
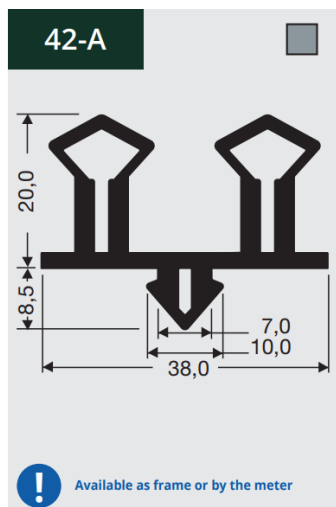
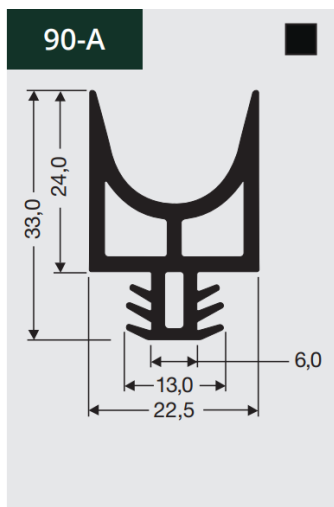

**701-A** ■

! Available per profile length of 1 meter

**702-A** ■

**703-A** ■

**704-A** ■

**893-A** □

**854-A** ■

**57-A** ■

! Available per profile length of 4 meters

**41-A** ■

! Available as frame or by the meter

**41-H** ■

! Corner for rubber profile 41-A  
Image not the actual size

**57-B** ■

! Available per profile length of 4 meters

## Demoväska med prover på tätningslister



En praktisk demoväska med fler än 100 provbitar av de mest använda kylprofiltyperna.

Med denna proffsiga provväska till hands är det lättare att avgöra den korrekta profilen direkt hos kunden. På så sätt undviker du att behöva göra återbesök för att provmontera en bit tätningslist innan beställning.

Mått: 440 x 350 x 120 mm

Vikt: 2 kg

Nettopris endast

**700 kr**

## Identifiera listen och ta rätt mått.

När du kontaktar oss är det viktigt att du ger oss korrekt information för att vi ska hitta rätt tätningsprofil.

Ska du ersätta en befintlig list skär upp den och ta en bild för att visa exakt hur profilen ser ut. Förutom längd och bredd, ge oss även ett relevant mått (A, B, C) se bild nedan. För alla Snap-in profiler är det bäst att ange c/c-måttet (C).

Använd gärna beställningsformuläret på nästa sida.

✓ Rätt

✗ Fel

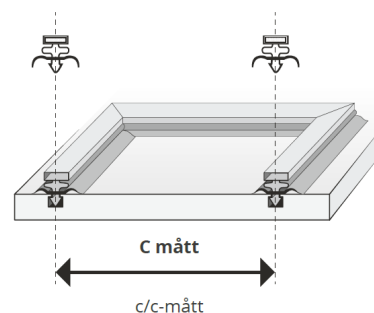
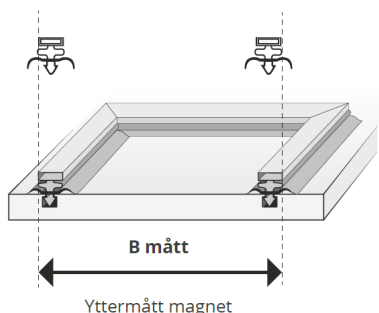
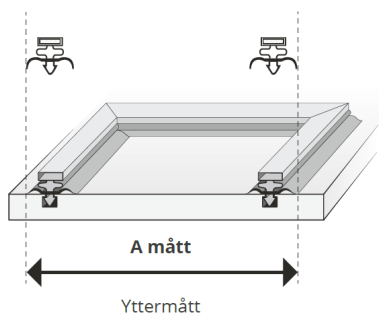
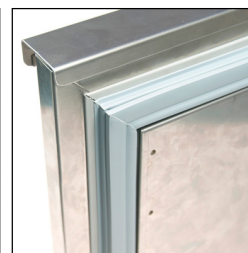

## Beställningsformulär

Datum

Företag

Beställare

Ordernummer

Kostnadsförslag  Order  Förfrågan

Antal	Profil nr.	Färg	Längd	Bredd	Mått	Märke	Referens
			cm	cm	<input type="checkbox"/> A <input type="checkbox"/> B <input type="checkbox"/> C		
			cm	cm	<input type="checkbox"/> A <input type="checkbox"/> B <input type="checkbox"/> C		
			cm	cm	<input type="checkbox"/> A <input type="checkbox"/> B <input type="checkbox"/> C		
			cm	cm	<input type="checkbox"/> A <input type="checkbox"/> B <input type="checkbox"/> C		
Exempel: 3	 34-M	Grå	40,4 cm	28,9 cm	<input type="checkbox"/> A <input type="checkbox"/> B <input checked="" type="checkbox"/> C	ZANUSSI	Låda stor referens 2714200

